

Z915B / Z915E / Z920M / Z925M EFI / Z925M FLEX FUEL Z930M EFI / Z930M / Z945M EFI / Z950M / Z955M EFI / Z960M Z920R / Z930R / Z950R / Z960R / Z970R

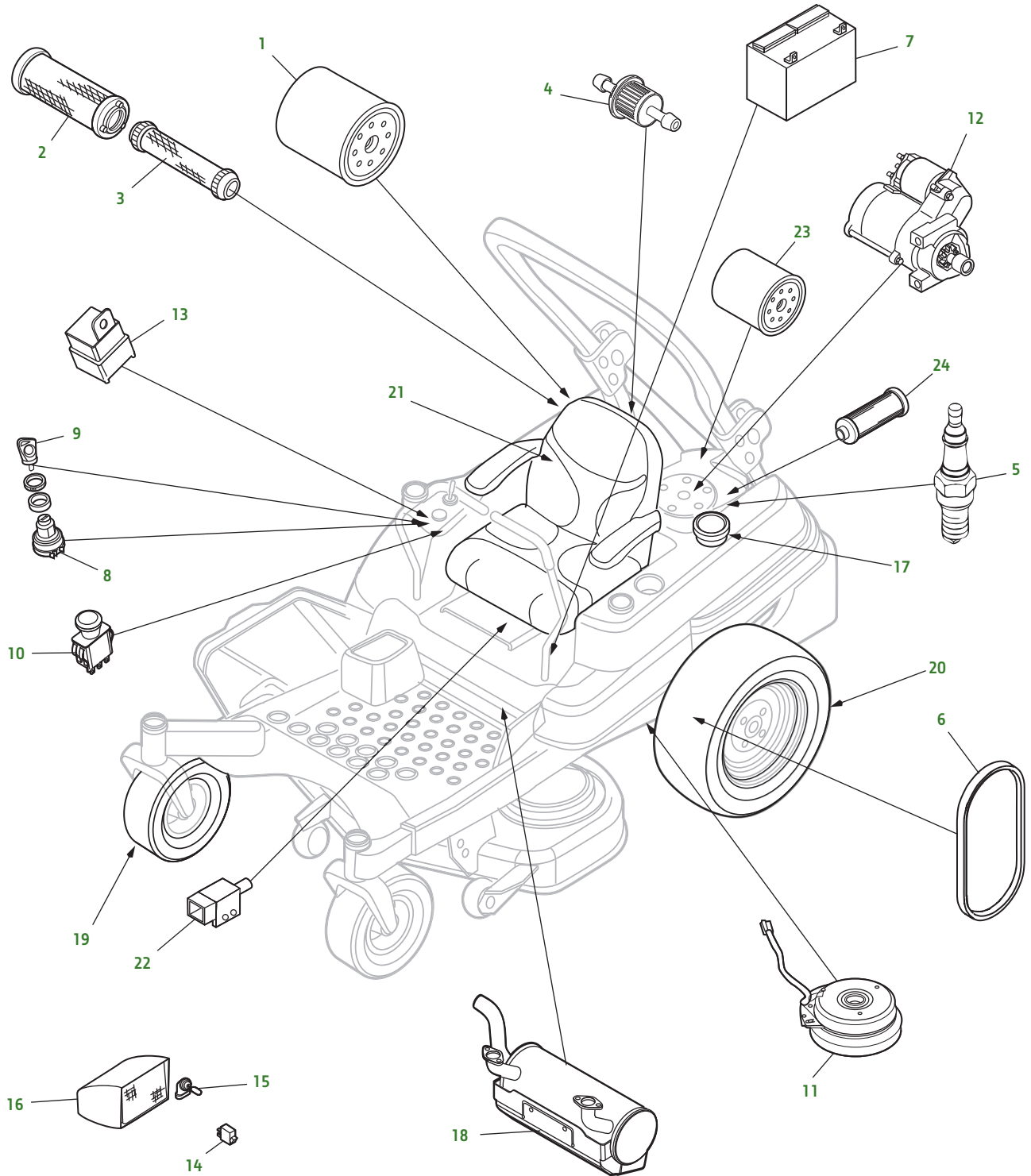

Z915B / Z915E / Z920M / Z925M EFI / Z925M FLEX FUEL Z930M EFI / Z930M / Z945M EFI / Z950M / Z955M EFI / Z960M Z920R / Z930R / Z950R / Z960R / Z970R

Key	Part No.	Description	Key	Part No.	Description
1	AM107423	ENGINE OIL FILTER - Z930M/R, Z950M/R, Z960M/R & Z970R			54 in (S/N 030001-), 60 in (S/N 030001-)] [48 in, 54in and 60in (S/N 030001-), [Z925M EFI 54 in, 60 in (S/N 030001-)] [Z930M EFI 60in], [Z930M 54in, 60in and 72 in], [Z945M EFI 60 in], [Z920R 48in, 54in], [Z930R 54in, 60in]
	AM125424	ENGINE OIL FILTER - Z915B, Z915E, Z920M/R, Z930M EFI, Z925M EFI & Z925M FLEX FUEL, Z945M EFI, Z955M EFI			
2	M131802	AIR FILTER - PRIMARY		AUC11007	PTO CLUTCH - [Z920M 60 in (S/N -030001)], [Z925M EFI 60 in (S/N -030001)], Z925M FLEX FUEL 60 in (S/N -030001)] [Z955M EFI, Z960M 60in, 72 in], [Z950R, Z960R, Z970R 60in, 72in]
3	M131803	AIR FILTER - SECONDARY	12	UC16212	STARTER - Z915B, Z915E, Z930M EFI, Z925M EFI & Z925M FLEX FUEL, Z945M EFI, Z955M EFI
4	MIU13224	FUEL FILTER - Z925M EFI, Z925M FLEX FUEL & Z930M EFI		AUC12656	STARTER - Z920M/R
	AM116304	FUEL FILTER		AUC12593	STARTER - Z930M/R, Z950M/R, Z960M/R & Z970R
	UC16183	FUEL FILTER - Z945M EFI, Z955M EFI, Z915B, Z915E	13	AM123716	RELAY - Z920M - Z960M
5	M805853	SPARK PLUG - Z920M/R, Z930M/R & Z950M/R		SJ15811	RELAY - Z920R - Z970R
	M802138	SPARK PLUG - Z960M/R & Z970R	14	AM117324	SWITCH - HEADLIGHT (OPTIONAL)
	MIU11020	SPARK PLUG - Z915B, Z915E, Z925M EFI, Z930M EFI, & Z925M FLEX FUEL	15	AM118013	HEADLIGHT BULB (OPTIONAL)
	UC16172	SPARK PLUG - Z945M EFI, Z955M EFI	16	AM125447	HEADLIGHT (OPTIONAL)
6	TCU34299	V-BELT - TRACTION DRIVE	17	TCA23672	FILLER CAP [(S/N -060000), Z915E, Z920M, Z925M FLEX, FUEL, Z930M, Z930M EFI, Z945M EFI, Z950M, Z955M EFI, Z960M, Z930R, Z950R, Z970R, Z925M EFI, Z930M EFI], Z915B, Z960R, Z920R
7	TY25221	BATTERY		AUC11638	FILLER CAP (S/N 060001-) Z915E, Z920M, Z925M FLEX FUEL, Z930M, Z930M EFI, Z945M EFI, Z950M, Z955M EFI, Z960M, Z930R, Z950R, Z970R
8	TCA22740	IGNITION SWITCH - (S/N -030000)	18	TCA21567	MUFFLER - Z915B, Z915E
	AUC13979	IGNITION SWITCH - (S/N 030001-), Z915E, Z945M EFI, Z955M EFI, Z960M		TCA21568	MUFFLER - Z920M/R
9	AUC12681	IGNITION KEY - (S/N -030000), Z915B, Z920M, Z970R, Z925M EFI, Z925M FLEX FUEL, Z930M EFI, Z930M, Z950M, Z930R, Z950R		TCA21569	MUFFLER - Z930M/R & Z950M/R
	TCA24616	IGNITION KEY - (S/N 030001-060000), Z915B, Z920M, Z925M EFI, Z925M FLEX FUEL, Z930M EFI, Z930M, Z950M, Z930R, Z950R, Z970R		TCA26233	MUFFLER - Z960M/R & Z970R
	AUC12681	IGNITION KEY - (S/N 060001-), Z915B, Z920M, Z925M EFI, Z925M FLEX FUEL, Z930M EFI, Z930M, Z950M, Z930R, Z950R, Z970R		TCA21571	MUFFLER - Z925M EFI, Z930M EFI & Z925M FLEX FUEL
	TCA24616	IGNITION KEY - (S/N -060000), Z915E, Z960M		TCA26234	MUFFLER - Z945M EFI, Z955M EFI
	AUC12681	IGNITION KEY - (S/N 060001-), Z915E, Z960M	19	TCA19309	CASTER WHEEL
	AUC12681	IGNITION KEY - Z945M EFI, Z955M EFI		TCA13769	CASTER WHEEL - Z915B, Z915E
	AUC12681	IGNITION KEY - (S/N -030000), Z920R, Z960R	20	TCU22802	TIRE REAR - [Z915B & Z915E (48in.)] & Z920M/R
	TCA24616	IGNITION KEY - (S/N 030001), Z920R, Z960R		TCU13631	TIRE REAR (24 X 12-12) -TURF MASTER
10	TCA21027	PTO SWITCH - (S/N 010000-040000)	21	TCA23663	SEAT ASSEMBLY
	AUC11003	PTO SWITCH - ROCKER STYLE - (S/N 040001-)	22	TCA15398	BRAKE SWITCH
11	TCA24445	PTO CLUTCH - [Z915B, Z915E 48 in . & 54 in], Z925M FLEX FUEL, 54 in (S/N -030001)	23	LVA16054	HYDRAULIC FILTER - Z920R-Z970R
	TCA24446	PTO CLUTCH - [Z915B,Z915E 60in], [Z925M FLEX FUEL,	24	MIA881446	HYDRAULIC FILTER KIT

Z915B / Z915E / Z920M / Z925M EFI / Z925M FLEX FUEL Z930M EFI / Z930M / Z945M EFI / Z950M / Z955M EFI / Z960M Z920R / Z930R / Z950R / Z960R / Z970R

Parts Needed in First 250 Hours of Operation

Qty	Part No.	Item	Capacity	Interval In Hours
3	AM125424	Engine Oil Filter - Z915B, Z915E, Z920M/R, Z930M EFI, Z925M FLEX FUEL & Z925M FLEX FUEL Z945M EFI, Z955M EFI		8/100/200
3	AM107423	Engine Oil Filter - Z930M/R, Z950M/R, Z960M/R & Z970R	1	8/100/200
6	TY22029	TURF-GARD™ 10W-30 Engine Oil	1.9 L (2 qt)	8/100/200
8		Z960R/Z970R (S/N 030001-), Z915B, Z915E, Z920M/R, Z925M EFI, Z925M FLEX FUEL & Z930M EFI	2.36 L (2.5 qt)	8/100/200
9		Z960R/Z970R (S/N -030000), Z930M/R & Z950M/R Z945M EFI, Z955M EFI	2.6 L (2.7 qt)	8/100/200
2	M131802	Air Filter - Primary	1	100/200
1	M131803	Air Filter - Secondary	1	200
1	AM116304	Fuel Filter	1	200
1	MIU13224	Fuel Filter - Z925M FLEX FUEL, Z925M EFI, Z930M EFI	1	200
1	UC16183	FUEL FILTER - Z945M EFI, Z955M EFI, Z915B, Z915E	1	200
3	TY6341	Multi-Purpose SD Polyurea Grease		As Needed

Capacities

Z900R Series Transmission Oil (With Filters).....	5 L (5.3 qt)
Z900B/E and Z900M Series Transmission Oil (With Filters).....	4.5 L (4.8 qt)
Engine Oil w/ Filter - Z915B & Z915E.....	1.6 - 1.8 L (1.7 to 1.9 qt)
Engine Oil w/ Filter - Z925M and Z930M EFI.....	1.6 - 1.8 L (1.7 to 1.9 qt)
Engine Oil w/ Filter - Z920M.....	2.0 L (2.1 qt)
Engine Oil w/ Filter - Z930M, Z950M, Z930R, and Z950R.....	2.3 L (2.4 qt)
Engine Oil w/ Filter - Z925M EFI, Z925M FLEX FUEL, Z960M, Z920R, Z960R, Z970R.....	1.9 L (2 qt)
Engine Oil w/ Filter - Z945M EFI, Z955M EFI.....	2.6 L (2.7 qt)
Grease Gun.....	TY26518

48 in. / 54 in. / 60 in. / 72 in. decks (Z900B - Z900R Series)

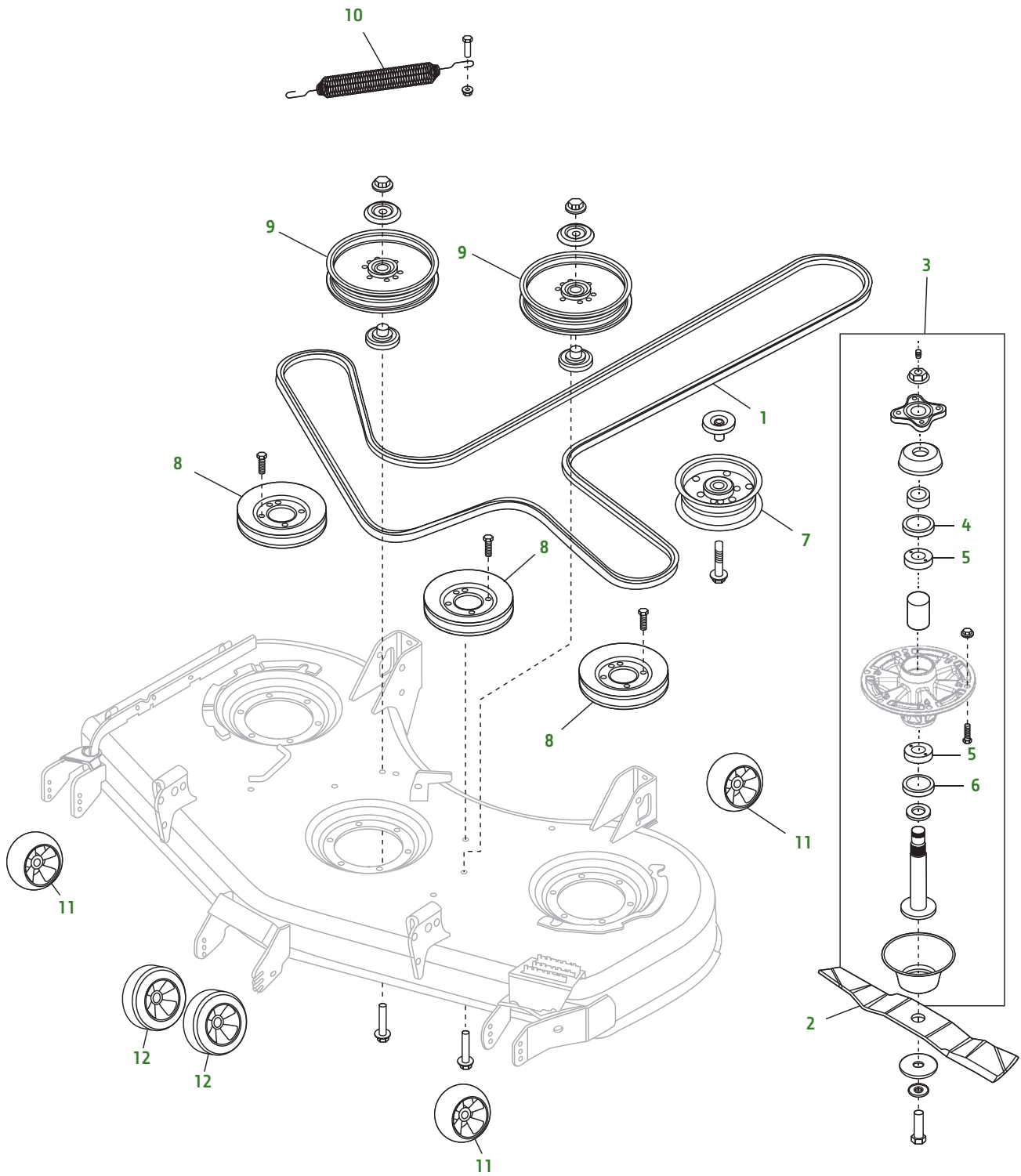

48 in. / 54 in. / 60 in. / 72 in. decks (Z900B - Z900R Series) (Continued)

Key	Part No.....Description	Key	Part No.....Description
1	TCU30510 BELT - 48 in.	3	TCA24880 SPINDLE KIT
	TCU31132 BELT - 54 in.	4	M85699 SEAL
	TCU35604 BELT - 60 in.	5	M169375 BEARING
	TCU31194 BELT - 72 in.	6	M127198 SEAL
2	TCU30315 BLADE - HIGH LIFT - 48 in.	7	TCA20602 IDLER
	TCU18678 BLADE - LOW LIFT - 48 in.	8	TCU26965 SHEAVE ASSEMBLY - 48 in.
	M136185 BLADE - MULCH - 48 in.		TCU28215 SHEAVE ASSEMBLY - 54 in.
	TCU21475 BLADE - MULCH ON DEMAND - 48 in.		TCU26967 SHEAVE ASSEMBLY - 60 in.
	M136194 BLADE - STANDARD LIFT - 48 in.		TCU26968 SHEAVE ASSEMBLY - 72 in.
	TCU30317 BLADE - HIGH LIFT - 54 in.	9	AUC11584 IDLER
	M135334 BLADE - MULCH - 54 in.	10	TCA22763 EXTENSION SPRING
	TCU30316 BLADE - STANDARD LIFT - 54 in.	11	TCU18744 GAGE WHEEL
	TCU15881 BLADE - HIGH LIFT - 60 in.	12	TCU34060 ROLLER
	M133381 BLADE - LOW LIFT - 60 in.		
	M168223 BLADE - MULCH - 60 in.		
	TCU18990 BLADE - MULCH ON DEMAND - 60 in.		
	M128485 BLADE - STANDARD LIFT - 60 in.		
	TCU15882 BLADE - HIGH LIFT - 72 in.		
	M141669 BLADE - LOW LIFT - 72 in.		
	M142514 BLADE - MULCH - 72 in.		

Frequently Used Items

Qty	Part No.	Item
3	TCA24880	Spindle Kit
3	TCU30315	Blade - High Lift - 48 in.
3	TCU18678	Blade - Low Lift - 48 in.
3	M136185	Blade - Mulch - 48 in.
3	TCU21475	Blade - Mulch On Demand - 48 in.
3	M136194	Blade - Standard Lift - 48 in.
3	TCU30317	Blade - High Lift - 54 in.
3	M135334	Blade - Mulch - 54 in.
3	TCU30316	Blade - Standard Lift - 54 in.
3	TCU15881	Blade - High Lift - 60 in.
3	M133381	Blade - Low Lift - 60 in.
3	M168223	Blade - Mulch - 60 in.
3	TCU18990	Blade - Mulch On Demand - 60 in.
3	M128485	Blade - Standard Lift - 60 in.
3	TCU15882	Blade - High Lift - 72 in.
3	M141669	Blade - Low Lift - 72 in.
3	M142514	Blade - Mulch - 72 in.
1	TCU30510	Belt - 48 in
1	TCU31132	Belt - 54 in
1	TCU35604	Belt - 60 in
1	TCU31194	Belt - 72 in